

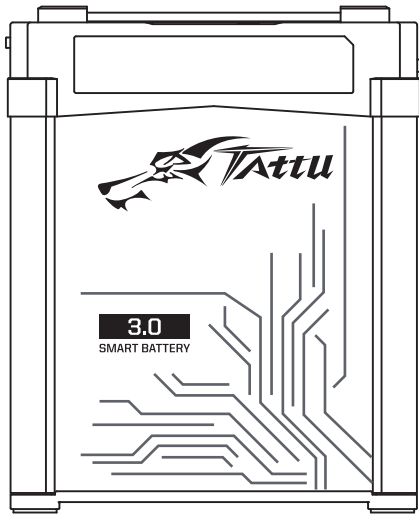

Smart Battery User Manual

Tattu 3.0

Thank you for purchasing this product, please carefully follow all instructions in this manual.



SHENZHEN GREPOW BATTERY CO.,LTD

※Lithium polymer batteries contain active substances that can easily cause fires without proper usage. TATTU manufacturer, distributors and dealers will not be held responsible or liable for any personal injury or property damage caused from improper usage of TATTU products without reading the instructions.

Telephone:
CN: +86 0755-88376372
DE: +49 (0)211 93670190
USA: +1 (925) 364-7166

Official E-mail:
info@grepow.com
info@gensace.de
info@genstattu.com

Product Description

Introduction:

The TATTU 3.0 is suitable for multiple drone systems. There are many smart features, which include data collection, safety reminder, power calculation, automatic balancing, charging reminder, abnormal-status alarm, data transmission, history check and more.

Product Parameters

Battery Type	Rechargeable lithium ion polymer battery pack		
Model	TA3TAS19K1425X	TA3TAS22K1425X	TA3TAS25K1425X
Nominal Capacity	19Ah	22Ah	25Ah
Battery Configuration	14S1P		
Typical Voltage	51.8V		
Size(L*W*H)	238* 174*117mm		
Battery Weight (±100g)	8000g	8900g	9700g
Power(Wh)	984.2Wh	1139.6Wh	1295Wh
Max.Continuous Discharge Current	100A	130A	150A
Peak Discharge Current	150A(<3S)	180A(<3S)	200A(<3S)
Recommended Charging Temperature	+10°C~+45°C		
Recommended Discharging Temperature	+10°C~+60°C		
Max.Charging Voltage	58.8V(4.2V/cell)		
Recommended Landing Voltage	50.4V(3.6V/cell)		
Recommended Forced Landing Voltage	49.7V(3.55V/cell)		

- 1 -

Product List

Battery Pack(1 PC)	Molex Charging Balance Converter (1 PC)	User Manual(1 PC)

Product Operational Guide

1. Overview

Top View



- ① Battery-Power Indicator
- ② LED 1-4 White Button
- ③ LED 5-7 Button with different colors

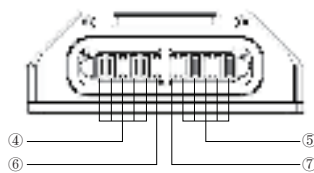

- ④ Discharge Positive
- ⑤ Discharge Negative
- ⑥ CAN_H
- ⑦ CAN_L

3D Diagram

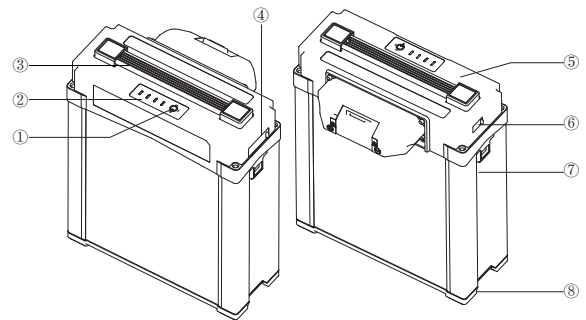

- ① Button
- ② Capacity Indicator
- ③ Handle
- ④ Equalizing port dust plug
- ⑤ Top case
- ⑥ USB Port
- ⑦ Aluminum frame
- ⑧ Bottom Shell

2. Indicator lights, button and balancing port

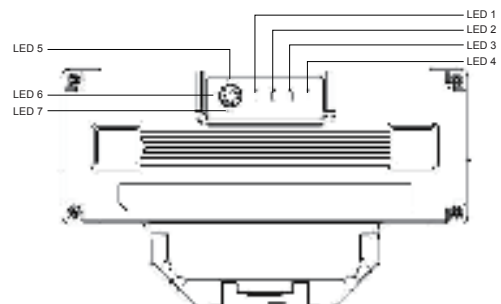

①LED1, LED2, LED3, LED4 are white lights and show the battery SOC and lifespan
②LED5, LED6, LED7 are red, orange, and white lights respectively and show the status of the battery's health

- 2 -

- 3 -



③ Description of Button Functions

Battery Status	Button Operation	Function
Power Off	Short press	Check remaining power
Power Off	Short press+long press($\geq 2s$)	LED on, LED shows the remaining power
Power On	Short press+long press($\geq 2s$)	LED off
Power Off	long press($\geq 5s$)	Shows battery lifetime

④ Definition of Balancing Port

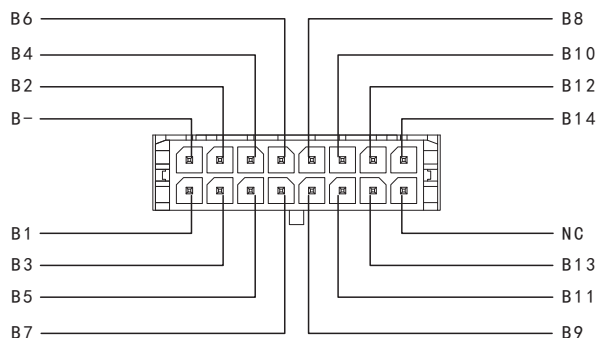

3. Operation Guide

① Check Battery's Remaining Power

* The LED lights will indicate the battery's remaining power

Remaining Power	LED1	LED2	LED3	LED4
0% ~ 12%	Blink	Off	Off	Off
13% ~ 24%	On	Off	Off	Off
25% ~ 37%	On	Blink	Off	Off
38% ~ 49%	On	On	Off	Off
50% ~ 62%	On	On	Blink	Off
63% ~ 74%	On	On	On	Off
75% ~ 94%	On	On	On	Blink
95% ~ 100%	On	On	On	On

— 4 —

4. Check Battery's Lifespan

- Sleeping mode reduces self-consumption and starts when the battery is inactive for 10 minutes after powering on. The battery can be activated again by charging and discharging.
- When any cell voltage is lower than 3.65V, the BMS will enter a second-class low-power consumption mode to ensure battery safety. If this ever occurs, you must charge the battery immediately in order to avoid irreversible damage.

5. Self-balancing Function

The self-balancing function is activated when the battery is left alone for more than 6 hours. In this mode, the voltage difference of each cell will meet the preset value.

6. Smart Storage Mode

The battery can be stored if the SOC LEDs show the modes below.

Remaining Power	White LED1	White LED2	White LED3	White LED4
50%~62%	On	On	Blink	Off
63%~74%	On	On	On	Off

The smart storage mode starts if the battery is left alone >6 days and/or if any cell voltages are >3.95V and the temperature is <60°C (It's the normal if the temperature rises during discharge). The smart storage mode stops once any cell voltages are $\leq 3.95V$, the temperature is $\geq 60^\circ C$, or with any charge and discharge action. Store the battery in a battery box, and do not store the battery for a long period of time after it has been completely discharged. This is to prevent the battery from an over-discharged state, which will cause cell damage. If the battery is left alone for more than 5 days, discharge the battery to 40-70% capacity for storage.

7. Common Failures And Troubleshooting Methods

Warnings	Description	Solution
Charging Over-current	When the battery charging current exceeds the design value	Check if the charger current setting is correct. Disconnect the connector between the charger and the battery, and the warning should disappear
Charging Over-current	Overcharge alarm will be triggered when the battery is fully charged, but charging will continue	The alarm will stop when the connector between the charger and battery is disconnected and the battery voltage drops to 4.18V/cell
Low temperature	The battery temperature is too low for charging	When the battery temperature rises above 15 °C, the alarm will stop
Battery High Temperature	The battery temperature is too high for charging	The alarm will stop when the battery is cooled below 45 °C

— 6 —

② Check Battery's Lifespan

* Press and hold the button for 5 seconds when the battery is powered off

Remaining Lifetime	LED1	LED2	LED3	LED4
88% ~ 100%	On	On	On	On
75% ~ 87%	On	On	On	Blink
63% ~ 74%	On	On	On	Off
50% ~ 62%	On	On	Blink	Off
38% ~ 49%	On	On	Off	Off
25% ~ 37%	On	Blink	Off	Off
13% ~ 24%	On	Off	Off	Off
Below 12%	Blink	Off	Off	Off

③ Charging

* Charging when power is on: the battery indicator will turn off 10 minutes after the battery is fully charged.

* Charging when power is off: the battery indicator will turn off after the battery is fully charged.

Remaining Power	LED1	LED2	LED3	LED4
0% ~ 12%	Blink	Blink	Blink	Blink
13% ~ 37%	On	Blink	Blink	Blink
38% ~ 62%	On	On	Blink	Blink
63% ~ 94%	On	On	On	Blink
95% ~ 100%	On	On	On	On

④ Status LED Indicator

· Red LED: Indicates that the battery is currently in storage mode.

· Orange LED: Error Warning indicating that battery needs to be maintained.

If LED lights are still on after maintenance, don't use the battery any further and contact the Tattu team.

Red LED5	White LED7	Description
Blink		Over Temperature warning Level 2, please stop charge or discharge till the temperature down to safe value.
	Blink	Over temperature warning Level 1, please stop charge or discharge till the temperature down to safe value.
On	On	Voltage difference warning Level 2, balance charging is required.
		Voltage difference warning Level 1, Balance charging is required.
On	On	False warning, please charge the battery by maintenance mode

— 5 —

Cautions

- The battery protection board is not equipped with anti-sparking function. If anti-sparking function is required, please use a connector with anti-spark function;
- When using the charger to charge the battery, the balancing current shall not be above 1A;
- The battery does not have the overcharge or over discharge protection function, and it is necessary to set the charge/discharge limit voltage on the charger or the device;
- Do not short-circuit the connector, otherwise there is a safety risk;
- The discharge cables shall be soldered well with connector, otherwise the power supply may be poor, and causing the aircraft to crash during the flight;
- Do not pull on the battery cables under any circumstances.
* Please read the following instructions carefully before use;
* Lithium polymer batteries are active substances and it is easy to cause fire without proper use. If improper use without reading the instructions and cause personal injury or property damage, TATTU manufacturers, distributors and dealers will not be responsible for any liability.
* To purchase TATTU related products, the buyer must bear all risks related to the product;
* If you do not agree to this clause, please return the battery to us immediately before use.

1. Using

- Before using the battery, please check the battery's power and health status (see content No.3, Operation Guide 1)
- Please check if the battery is damaged, bulging or leaking. If any of the above, do not use it;
- Do not let the battery contact metal and carbon fiber products to prevent short circuit;
- Do not short or reverse the positive and negative electrode;
- Do not pull the battery charge / discharge cables;
- Do not assemble the battery by your own, Reassemble the old battery cell or reorganize one of the disassembled cells to another pack is dangerous (It's easy to cause short-circuit and cause fire);
- In the low temperature environment (below 5 °C), it is recommended to preheat the battery by charging or discharging the battery with small current to above 5 °C before use, 20 °C is best, do not do heavy duty operations when first starting use of a cold pack. Allow the battery to reach normal operating temperatures before hard use.
- Do not over-discharge the battery (single-cell voltage should not be lower than 3.3V), over-discharge will damage the battery easily, such as puffing, etc;
- Do not splash the electrolyte on your eyes or skin. If this occurs flush with water and seek medical advice immediately.

2. Charging

- ONLY use a Li-Po battery type smart charger to charge
- It is recommended to charge in the temperature range of 10 °C to 45 °C;
- When charging, only use a table or platform that is heat-resistant. It is recommended to use an explosion-proof LIPO battery bag.
- Do not leave LiPo batteries unattended while charging

3. Storage

- Do not keep battery near liquid as well as store them in a humid place;
- Do not place the battery near heat sources such as open flames or heaters;
- Please Keep the battery out of the reach of children;
- Store the battery in a temperature controlled environment of approximately 25°C;
- Make sure that the battery has enough storage space (do not stack batteries in storage)
- If the battery is not used for a long time, it is recommended to do a charge cycle. Charge and discharge the battery to storage level(3.6-3.9v for single cell) every 3 months. This will ensure the best service life of the Battery.

— 7 —